

## C-2000 Case Erector

### Success Story

"After evaluating all the different machines at Pack Expo, I was convinced that the Lantech case erector was the only one there that would solve my problems".

-- Plant Manager, Large Fully Automated Dairy Plant

### Problem

15 – 20 % of production capacity lost due to frequent machine jams on new in-line automatic case erector.

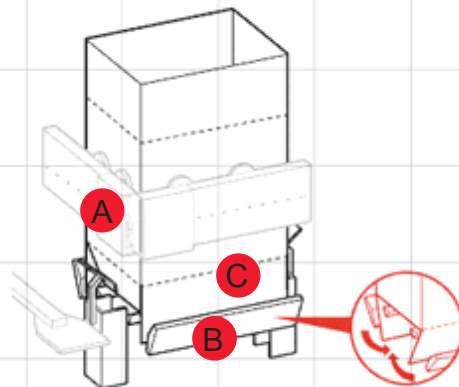

### Solution

Lantech's C-2000 fully automatic case erector eliminated the root causes of machine jams; variances in size and shape that occurs from case to case, and case mis-alignment during the sealing process



### Benefits

- Ergonomic design of magazine allows easy loading of blanks.
- Compact, small footprint
- Adjustment wheels, counters and "Help" chart makes case adjustments easy to do.
- Three Year, Unlimited Cycle "Built Tough" Warranty



### A Powerful Difference

Positive control of case pick-up and folding operation stops machine jams and costly downtime.

Lantech's C-2000 Case Erector is designed to minimize machine jams. See illustration of the dependable case erecting process: (A) Unique hinged pick-up and folding frame that reliably opens cases by placing erecting frame suction cups on two panels of the case to keep the case square. (B) Innovative slotted flap folders fold majors along entire length for maximum control, and (C) All flaps folded while case is held square in the erecting frame.

The root causes for the dramatic loss of production capacity at the dairy plant were immediately eliminated and demanding order requirements from major retail grocery chains were fulfilled. After the new Lantech C-1000 Automatic Case Erector was installed, the Plant Manager had this to say about the results, "Now we get orders out the door on time, everyday".

Visit us at  
[www.lantech.com](http://www.lantech.com)  
to view product  
specifications  
and options